

Name: _____

daughter d a u g h t e r d d n d a u g h e r j q

sauce u s a u c e s u a c u e c z r c s u k e

wonderful q u n f z o d w o n d e r f u l r d f d

restaurant y e t r r a r e s t a u r a n t t i h b

print i t r n p r i h n p r i n t z r p q i i

government g o v e r n m i n t g o v e r n m e n t

cube e c b e c c c d g e x p c u b e r b l m

the e t h e h t h e h t h t h e h j z n i b

pause k d e m s n p a s e s g p u a p a u s e

cash s i x k a h s n r h f y a v b a c a s h

fox e g o f o x q f x o x f s u o f o s f b

then z v h y b t h e n g s t h e e n l h a n

cause b c c o i s i u u j d x p c a u s e s e

if i f g e i f f i f a i d i m f x w h e f

excitement b e x n c n x v e x c i t e m e n t e e

these t h e s e s f e l h t e e h e s e w y e

thankful k t h a n k f u l l u t h a n k f u l b

environment y x n t m n u e n v i r o n m e n t h r

awful x m a l w q l a w e f u l u a w f u l i

color o c u l o r c o l o r e o a j k c m o g

erosion e r r o s s i o n s n n e r o s i o n e

helpful t k h e l p f u l h e l f p u l h a h e

causes k u c a u s i s c x c a u s e s m u t e

Name: _____

Use each word ONCE. Cross off each word after it is used.

excitement • thankful • awful • fox • sauce • cause • daughter
government • erosion • color • cube • restaurant • these • then
environment • if • print • pause • wonderful • helpful • causes

These words have "au" in them.

_____ a u _____

These words have "ful" in them.

_____ f u l _____

_____ f u l _____

These words have "nment" in them.

_____ n m e n t _____

These words have "ause" in them.

_____ a u s e _____

These words have the short u sound like in cover.

_____ o _____

Fit the rest of the words into these shapes.

		i	n	t

i	
---	--

--	--	--	--

--	--	--	--

--	--	--	--	--

--	--	--

Name: _____

Read the topic. Fill in the boxes with your ideas.

Topic: Sketch Book Came to Life

Your sister is a great artist. She draws in a sketch book. Today her sketch book came to life. What happened?

The drawings in the book

What they did when they first came to life

lap • grandmother • to • ask • do • going • cane • make • pain
birthday • doing • in • they • cat • being • sack • tip

the sound of i in mitten	the sound of a in baby	the sound of a in glass	does not fit
_____	_____	_____	_____
_____	_____	_____	_____
_____	_____	_____	_____
_____	_____	_____	_____
_____	_____	_____	_____

Combine the words to make a compound word.

turn + pike = _____

over + time = _____

9+60+500

90+1+700

Name: _____

Now write a paragraph using the ideas you have already written down.

Topic: Sketch Book Came to Life

Your sister is a great artist. She draws in a sketch book. Today her sketch book came to life. What happened?

Write a word problem for
 $15 - 5 = 10$.

$$\begin{array}{r} 33 \\ + 41 \\ \hline \end{array}$$

What is the largest two-digit
number you can make with
the numbers 3, 3, and 7?
_____Write an addition number
sentence using the numbers 4,
7, and 11.

$57 + 98 = \underline{\hspace{2cm}}$

ten more
than 225

$10 + 82 = \underline{\hspace{2cm}}$

$71 - 17 = \underline{\hspace{2cm}}$

100 less
than 778

$$\begin{array}{r} 45 \\ - 20 \\ \hline \end{array}$$

word root **tort** can mean **twist****contort, contortion, distortion**

Name: _____

Which way does each word go? Write the word.

<p>1. → COULD ↓ CHICKENS ← COOK</p>	<p>1. ↓ GOING → GAVE ← GAS</p> <p>2. KNEE → KEEP KNOCK</p>																																																																																																																																
<table border="1" style="margin: auto; border-collapse: collapse;"> <tr><td></td><td></td><td></td><td>¹C</td><td>O</td><td>U</td><td>L</td><td>D</td></tr> <tr><td style="background-color: #cccccc;"></td><td style="background-color: #cccccc;"></td><td style="background-color: #cccccc;"></td><td></td><td style="background-color: #cccccc;"></td><td style="background-color: #cccccc;"></td><td style="background-color: #cccccc;"></td><td style="background-color: #cccccc;"></td></tr> <tr><td style="background-color: #cccccc;"></td><td style="background-color: #cccccc;"></td><td style="background-color: #cccccc;"></td><td></td><td style="background-color: #cccccc;"></td><td style="background-color: #cccccc;"></td><td style="background-color: #cccccc;"></td><td style="background-color: #cccccc;"></td></tr> <tr><td style="background-color: #cccccc;"></td><td style="background-color: #cccccc;"></td><td style="background-color: #cccccc;"></td><td></td><td style="background-color: #cccccc;"></td><td style="background-color: #cccccc;"></td><td style="background-color: #cccccc;"></td><td style="background-color: #cccccc;"></td></tr> <tr><td style="background-color: #cccccc;"></td><td style="background-color: #cccccc;"></td><td style="background-color: #cccccc;"></td><td></td><td style="background-color: #cccccc;"></td><td style="background-color: #cccccc;"></td><td style="background-color: #cccccc;"></td><td style="background-color: #cccccc;"></td></tr> <tr><td style="background-color: #cccccc;"></td><td style="background-color: #cccccc;"></td><td style="background-color: #cccccc;"></td><td></td><td style="background-color: #cccccc;"></td><td style="background-color: #cccccc;"></td><td style="background-color: #cccccc;"></td><td style="background-color: #cccccc;"></td></tr> <tr><td style="background-color: #cccccc;"></td><td style="background-color: #cccccc;"></td><td style="background-color: #cccccc;"></td><td></td><td style="background-color: #cccccc;"></td><td style="background-color: #cccccc;"></td><td style="background-color: #cccccc;"></td><td style="background-color: #cccccc;"></td></tr> <tr><td style="background-color: #cccccc;"></td><td style="background-color: #cccccc;"></td><td style="background-color: #cccccc;"></td><td></td><td style="background-color: #cccccc;"></td><td style="background-color: #cccccc;"></td><td style="background-color: #cccccc;"></td><td style="background-color: #cccccc;"></td></tr> </table>				¹ C	O	U	L	D																																																									<table border="1" style="margin: auto; border-collapse: collapse;"> <tr><td>S</td><td>A</td><td>¹G</td><td></td><td></td><td></td><td style="background-color: #cccccc;"></td><td style="background-color: #cccccc;"></td></tr> <tr><td style="background-color: #cccccc;"></td><td style="background-color: #cccccc;"></td><td></td><td>²</td><td></td><td></td><td></td><td style="background-color: #cccccc;"></td></tr> <tr><td style="background-color: #cccccc;"></td><td style="background-color: #cccccc;"></td><td></td><td></td><td></td><td></td><td style="background-color: #cccccc;"></td><td style="background-color: #cccccc;"></td></tr> <tr><td style="background-color: #cccccc;"></td><td style="background-color: #cccccc;"></td><td></td><td></td><td></td><td></td><td style="background-color: #cccccc;"></td><td style="background-color: #cccccc;"></td></tr> <tr><td style="background-color: #cccccc;"></td><td style="background-color: #cccccc;"></td><td></td><td></td><td></td><td></td><td style="background-color: #cccccc;"></td><td style="background-color: #cccccc;"></td></tr> <tr><td style="background-color: #cccccc;"></td><td style="background-color: #cccccc;"></td><td></td><td></td><td></td><td></td><td style="background-color: #cccccc;"></td><td style="background-color: #cccccc;"></td></tr> <tr><td style="background-color: #cccccc;"></td><td style="background-color: #cccccc;"></td><td></td><td></td><td></td><td></td><td style="background-color: #cccccc;"></td><td style="background-color: #cccccc;"></td></tr> <tr><td style="background-color: #cccccc;"></td><td style="background-color: #cccccc;"></td><td></td><td></td><td></td><td></td><td style="background-color: #cccccc;"></td><td style="background-color: #cccccc;"></td></tr> </table>	S	A	¹ G									²																																																				
			¹ C	O	U	L	D																																																																																																																										
S	A	¹ G																																																																																																																															
			²																																																																																																																														

Take a guess and estimate how many squares are below. Then write the actual number.

Estimate: _____ Actual: _____

How close was your guess? _____

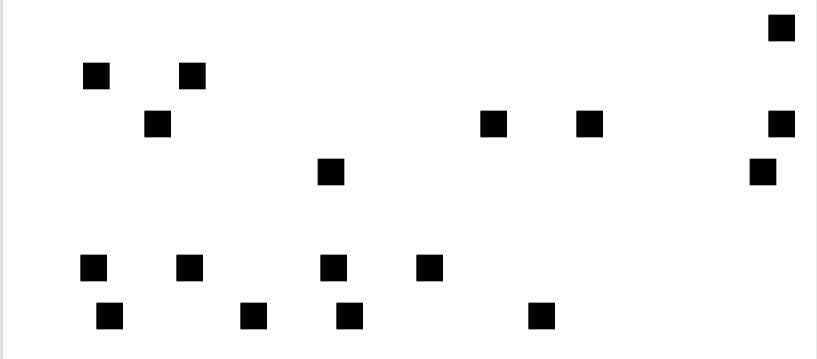

The Holly River is 83 miles long. The river flows east for 31 miles. It flows southeast the rest of its length. How many miles does it flow southeast?

80 - 71 = _____

9 tens and 2 ones

92 2 29

seventy-three

72 71 73

19 + _____ = 21

7 2 5

word root **mob** can mean **move** **mobilize, immobile**

Name: _____

Write these spelling words in ABC order:

cause • pause • excitement • print • thankful • erosion

1. _____

4. _____

2. _____

5. _____

3. _____

6. _____

Unscramble the letters to spell a word.

teh _____

nlfuathk _____

rwoludnfe _____

iecmnexett _____

hacs _____

seuac _____

fuwal _____

orclo _____

irtnp _____

fi _____

rtauaentsr _____

reinsoo _____

uspea _____

uasce _____

netmrnieonv _____

uesasc _____

ugdhaterr _____

hent _____

beuc _____

hleulpf _____

Name: _____

Today is _____.

April

May

June

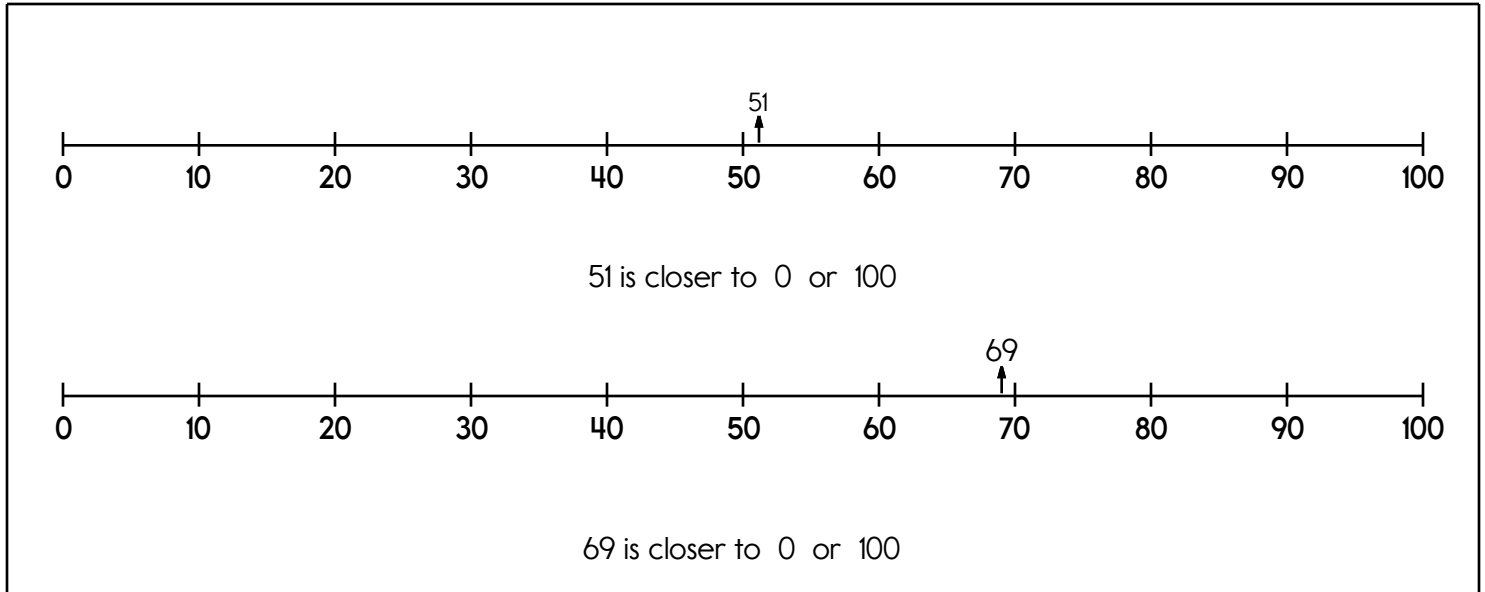

Complete the pattern.

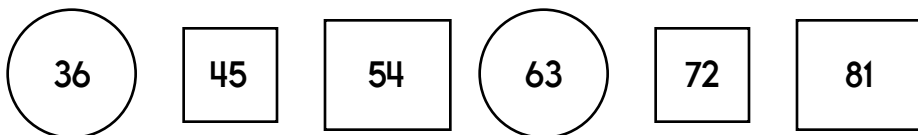
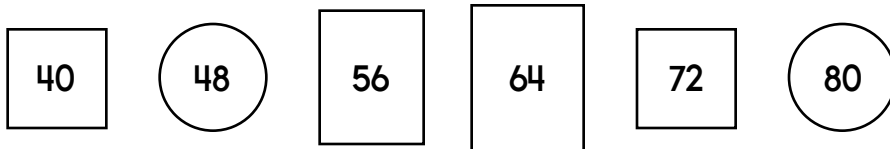
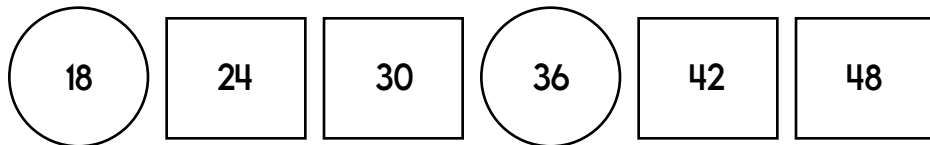
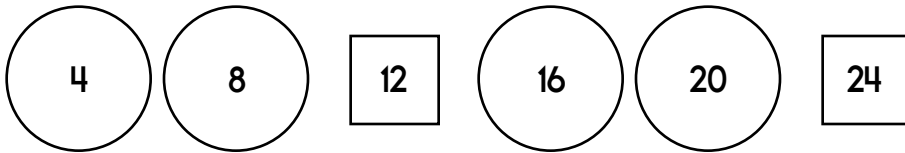

word root **cred** can mean **believe** **credence, credulous, incredible**

Name: _____

Write a story that follows the topic and picture.



Topic: Lost Dog

Write a paragraph: _____

Start each with 36.

Write 1 more _____

Write 1 less _____

Write 10 more _____

Write 10 less _____



Write the hidden word. Start at one letter and then move either left or right.

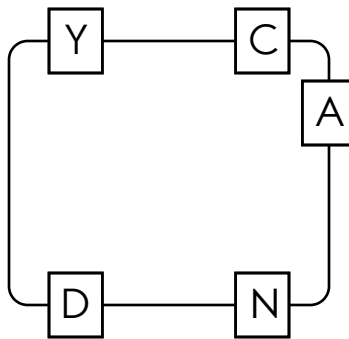

$$\begin{array}{r} 4 \\ 4 \\ + 71 \\ \hline \end{array}$$

$$\begin{array}{r} 23 \\ + 33 \\ \hline \end{array}$$

Rose ate 6 carrots. Then she ate 4 more carrots. How many carrots did she eat in all?

It is your turn. Write X to make your move.

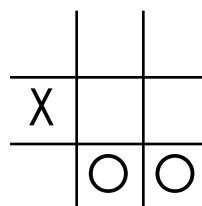

$$\begin{array}{r} 27 \\ + 93 \\ \hline \end{array}$$

word root **pre** can mean **before** **predict, prelude**